

Proposal of 2nd DPR under PMAY (BLC), Tripura

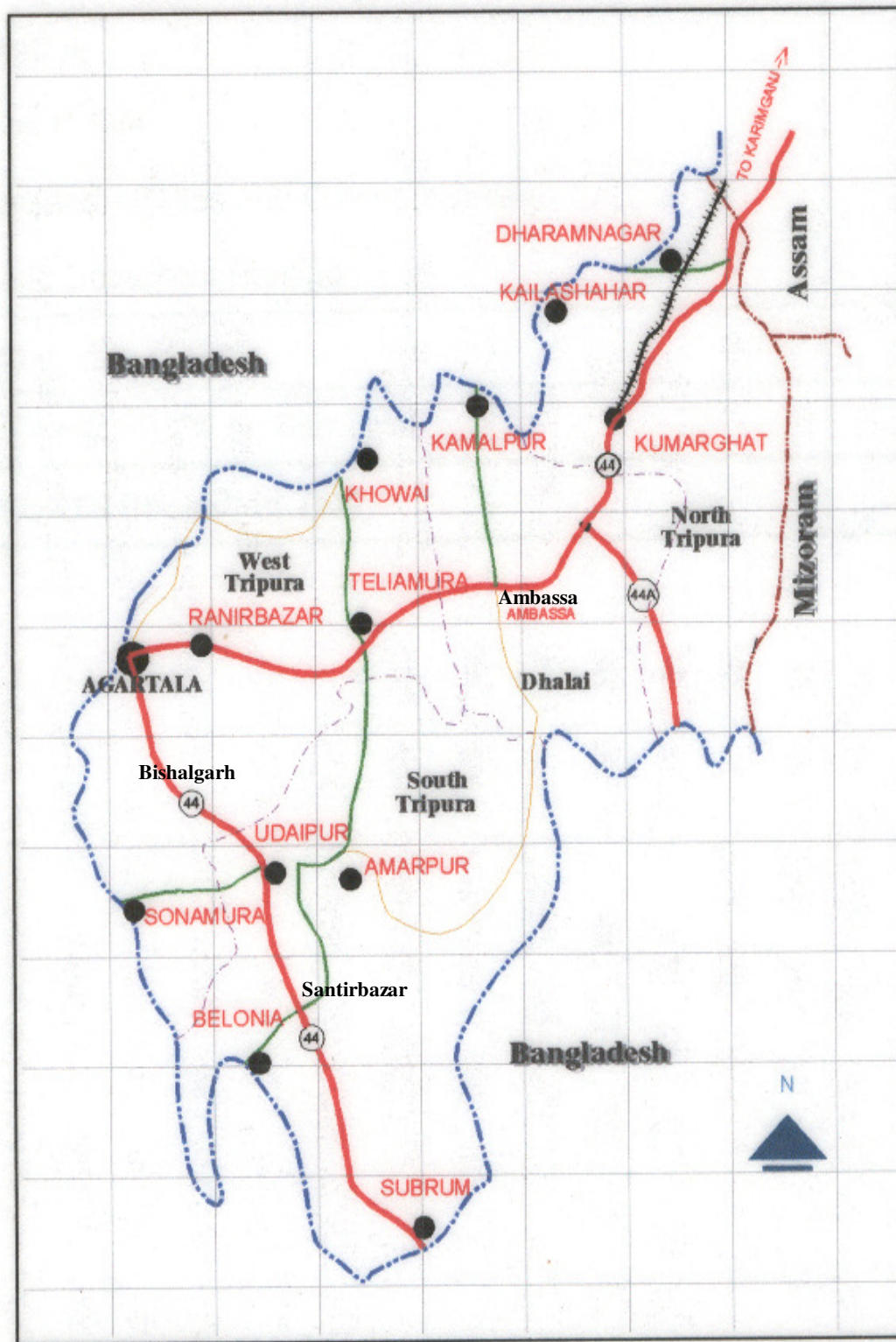

Meeting of CSMC, 30th Oct, 2017

Location of ULBs



Urban Profile of Tripura

- Urban population: 21% of total Population.
- Statutory towns: 20 (1 Corporation, 13 Municipal Councils & 6 Nagar Panchayats).
- Elections held: Dec 2015.
- Other Schemes: Agartala- ADB, AMRUT & Smart City. All 20 Cities are covered under SBM (U), DAY-NULM, 10% LS, TUEP, FFC Grants, SoT, SDS.
- Problems: Geographical isolation; Transportation bottleneck. Prolonged rainy season. Construction materials have to be brought from outside.
- Supervision : A dedicated Engineering Wing headed by a Chief Engineer.

Achievements so far

Scheme	Sanction yr	DUs constructed	Remarks.
IHSDP	2007-08 to 2009-10	3115 (in 5 towns)	All completed. 100% occupied. <u>Awards:</u> 2011-12 (for Teliamura), 2012-13 (for Sonamura).
BSUP	2008-09	256 (at Agartala)	All completed. 100% occupied. Awarded in 2010-11.
10% Lumpsum	2010-11	192 (at Radha Nagar)	In progress. 3rd instalment of CA awaited (Rs. 6.59 cr)
10% LS	2013-14	763 (at Dharmanagar)	In progress. 3rd instalment of CA awaited. (Rs.20.02 crore).
RAY	2014-15	3005 (in 4 towns)	In progress. 3rd instalment of CA awaited. (Rs.17.98 crore).
TSGHS	2013-14 & 2015-16	3500 (at 16 ULBs)	State Govt Scheme. All DUs completed.

HOUSING FOR ALL - PLAN OF ACTION (HFA PoA) for BLC vertical (New Houses)

Sl. No	Name of the vertical	No. of cities /towns	Year	No. of Houses	Project Cost (Rs. In lakhs)	GoI Grant (Rs. In lakhs)	State Share (Rs. In lakhs)	Beneficiary contribution (Rs. In lakhs)	Status
1	BLC (1 st DPR)	20	1916-17	42,896	116418.89	64344.00	7149.05	44925.84	Ongoing
2	BLC (2 nd DPR)	20	1917-18	32,876	89224.81	49314.00	5479.11	34431.69	Proposed for approval
Total-				75,772	205643.70	113658.00	12628.16	79357.53	

Progress of BLC (1st DPR)

- Total units sanctioned – 42,896
- Construction undertaken - 32,699 (76%)
 - Foundation Level - 6,965
 - Lintel Level - 8,389
 - Roof Level - 17,345
 - Completed - 3,005
 - Yet to start - 10,197
 - Dropouts - 6,649

Sample houses under PMAY(BLC)



ULB Name- Melaghar, Beneficiary Name-
Litan Miah,

ID- 162721132291300063



ULB Name- Sonamura , Beneficiary
Name-Abdul Barek,

ID-168015252375200043



**ULB Name- Sonamura, Beneficiary Name
Biswajit laskar, ID-168015252375200067,**



**ULB Name-Sabroom, Beneficiary Name- Shipra Rani
Roy, Beneficiary Code-68015302305800081**



**Beneficiary Name- Mrinal acharjee,
Beneficiary ID-168015252375100048**



**Beneficiary Name-Pumpu Das ,Beneficiary ID-
168015252375300082**

2nd DPR

Demand Assessment

- Demand Assessment Survey for Housing and sanitation conducted in **January 2016**.
- **2,07,791** urban families were surveyed Door-to-Door (100%).
- Findings:

Total ULBs	Households having	
	Kutcha Houses	Semi-pucca Houses
20	48,512	28,608

- SECC 2011: 23.5% of urban Houses have **grass/ thatch/ bamboo** and another 18.6% have **mud/ unburnt bricks** as predominant wall material.

Process of preparation of DPR

- Beneficiaries under BLC (New) identified as per Mission Guidelines.
- . There is no duplication of benefits across the verticals.
- All 20 DPRs prepared with complete list of beneficiaries with details including Aadhaar Nos, Beneficiaries' bank accounts no etc.
- Identified beneficiaries & applications received through newspaper advertisement displayed in ward offices. Claims & objections invited through newspaper publicity.

Present proposal – 2nd DPR-PMAY(BLC)

Sl No	No. of Towns (ULBs)	No. of Projects	No. of Dwelling units
1	20	20	32810+66 =32876

Abstract of cost (per BLC house)

Sl	Issue	Cost
1	Estimated cost	Rs. 2, 71,398.00
2	Rate index	SOR- 2011 (R&B) plus 20% cost
3	Method	Directly by the beneficiary
4	Cost of dwelling unit including Sanitary Block	Rs.2, 64,524.00
5	Add anticipated Cost Index 20%	Rs.52, 905.00
6	Total	Rs.3, 17,429.00
7	Less for Contractor's Profit	Rs.46, 031.00
8	Net cost	Rs. 2, 71,398.00

Cost sharing (each unit)

(Rs lakh)

Total cost of the DU	Central assistance	State's contribution	Beneficiary's contribution
2.71	1.50	0.17	1.04

- The proposal duly **appraised** by SLAC and **approved** by SLSMC

Proposed projects of ULBs- 2nd DPR (New)

(in Rs. Lakhs)

Sl No.	City	No. of Beneficiary					Total project cost (@ 2.71398)	GoI Grant (@ 1.5)	State Share (@0.16666)	Beneficiary Contribution (@1.04732)
		GEN	SC	ST	OBC	TOTAL				
1	Agartala MC	9850	6191	342	3464	19847	53864.36	29770.50	3307.70	20786.16
2	Amarpur NP	210	114	3	111	438	1188.72	657.00	73.00	458.73
3	Ambassa MC	245	158	82	202	687	1864.50	1030.50	114.50	719.51
4	Belonia MC	571	206	0	276	1053	2857.82	1579.50	175.49	1102.83
5	Bishalgarh MC	439	144	0	139	722	1959.49	1083.00	120.33	756.17
6	Dharmanagar MC	672	195	2	471	1340	3636.73	2010.00	223.32	1403.41
7	Jirania NP	34	34	6	28	102	276.83	153.00	17.00	106.83
8	Kailasahar MC	577	405	7	406	1395	3786.00	2092.50	232.49	1461.01
9	Kamalpur NP	89	273	0	540	902	2448.01	1353.00	150.33	944.68
10	Khowai MC	15	15	0	51	81	219.83	121.50	13.50	84.83

Sl No.	City	No. of Beneficiary					Total project cost (@ 2.71398)	GoI Grant (@1.5)	State Share (@0.16666)	Beneficiary Contribution (@1.04732)
		GEN	SC	ST	OBC	TOTAL				
11	Kumarghat MC	70	124	12	127	333	903.76	499.50	55.50	348.76
12	Melaghar MC	602	445	1	211	1259	3416.90	1888.50	209.82	1318.58
13	Mohanpur MC	125	241	0	201	567	1538.83	850.50	94.50	593.83
14	Panisagar NP	62	116	0	73	251	681.21	376.50	41.83	262.88
15	Ranirbazar MC	183	122	1	227	533	1446.55	799.50	88.83	558.22
16	Sabroom NP	154	65	2	51	272	738.20	408.00	45.33	284.87
17	Santirbazar MC	217	287	35	109	648	1758.66	972.00	108.00	678.66
18	Sonamura NP	591	204	4	186	985	2673.27	1477.50	164.16	1031.61
19	Teliamura MC	353	182	3	400	938	2545.71	1407.00	156.33	982.39
20	Udaipur MC	245	102	0	110	457	1240.29	685.50	76.16	478.63
Sub Total-						32810	89045.68	49215.00	5468.11	34362.57

Additional 2nd DPR (part) for Sonamura ULB

Sl No.	City	No. of Beneficiary					Total project cost (@ 2.71398)	GoI Grant (@ 1.5)	State Share (@0.16666)	Beneficiary Contribution (@1.04732)
		GEN	SC	ST	OBC	TOTAL				
11	Sonamura MC	39	03	0	24	66	179.12	99.00	10.99	69.13
Grand Total- (continue from pre-page)						32876	89224.80	49314	5479.10	34431.70

Implementation Strategy

- Construction will be completed in **12 months** by Beneficiaries themselves under supervision and active guidance of Engineering Wing of Department.
- **Geo-tagging** of photographs on completion of each milestone will be monitored by SLNA.
- Mission Director registered on PFMS portal
- Funds will be released by ULB direct (**DBT**) to Beneficiary's Bank account **on milestone basis**
- Low cost & innovative technologies will be tried.
- Civic amenities being provided by convergence

Status of mandatory reform under PMAY

Sl	Conditions (Either through Executive Order/Notification/ Legislation)	Status
1	State shall remove the requirement of separate Non Agricultural (NA) Permission in case land falls in the residential zone earmarked in the Master Plan of city/town.	Tripura Building Rules 2004 being amended to make provision. Being placed before next meeting of Council of Ministers.
2	States shall prepare/amend the Master Plans earmarking land for Affordable Housing.	Necessary process in this regard is advanced stage.
3	State shall put in place a single-window time bound clearance system for layout approvals and building permissions.	Achieved
4	States shall adopt pre-approved building permission and layout approval system for EWS/LIG housing or exempt approval below certain built up area /plot area.	Model design/Plan under PMAY pre-approved by Urban Local Bodies. Necessary changes for such pre-approved plan also being incorporated in Tripura Building Rules.
5	States shall legislate or amend existing rent laws on the lines of the Model Tenancy Act circulated by the First Party.	Awaiting GoI suggestion.
6	States shall provide additional Floor Area Ratio (FAR)/Floor Space Index (FSI)/ Transferable Development Rights (TDR) and relax density norms, for slum redevelopment and low cost housing	The provision for relaxation of any Rule like FAR etc. under Tripura Building Rules,2004 is already there.

ADHERENCE TO THE CONDITIONS

Sl. No	Condition	Adherence
1	All proposed projects are on litigation free land?	Yes, under BLC each beneficiary have their own land.
2	Status of Demand Survey, and timeline for completion, if not completed yet	Completed for BLC.
3	If Demand Survey is complete, has the state shared the list of CLSS beneficiaries to the Ministry?	List of BLC beneficiaries shared. CLSS under preparation
4	whether beneficiaries have been identified and listed in the DPR in conformity with SECC data?	Yes
5	Timelines for Project Completion (Months) For all BLC Projects timelines must be within 2 years of release of funds from Government of India.	Yes, 12 months for BLC projects subject to continuous flow of fund .
6	Status of Physical Infrastructure like drainage, road, street lighting, solid waste management, etc? If not available, whether the provision has been made in the project on this account?	Project is linked with existing infrastructure . In Agartala infrastructure being augmented by ADB, AMRUT and SMART city projects.
7	Whether the convergence with other centrally assisted programmes for provision of Infrastructure?	Yes, in some ULBs with Swachh Bharat Mission and AMRUT.

Sl. No	Condition	Adherence
8	Whether connection to Electricity & Water Supply has been planned under the project? The project shall not be considered complete unless them Houses are provided with Electricity & Water Supply.	Yes, all the dwelling units will be provided with individual toilets, water connection and electricity.
9	Status of Social Infrastructure?	Existing in the proposed areas.
10	Beneficiary details compiled as per Annexure 4B?	Yes.
11	Project Proposals submitted as per Annexure 7C?	Yes.
12	Whether the DPR contains the Financial details/Funding pattern of the Project?	Yes.
13	Details of the proposed ownership of houses – in favor of Women/Joint ownership	Yes.
14	Any other innovative approach taken by the state in proposed projects?	Award for best quality house.
15	Whether the Project Proposals are consistent and adhere to Guidelines in all aspects?	Yes.

Technical specifications:

- **Unit dimension:** 30 sq m. (5.35 m x 5.55 m)
- **Structural safety:** Depth of foundation kept sufficient for Tripura site condition. Wall thickness kept optimal. RCC lintel of acceptable quality. GCI sheet roofing of sufficient thickness, tied with J or L hook with washer as per safety norms. Steel tubular truss provided for structural stability and reducing fire hazard.
- **Compliance to NBC norms:** The unit has been designed in compliance with IS standards / NBC Guidelines & tested in Tripura condition.
- **Design:** Design and construction of houses to be disaster resilient particularly earthquake proof

CONSTRUCTION OF DWELLING UNIT
UNDER PRADHAN MANTRI AWAS
YOJANA, HOUSING FOR ALL URBAN

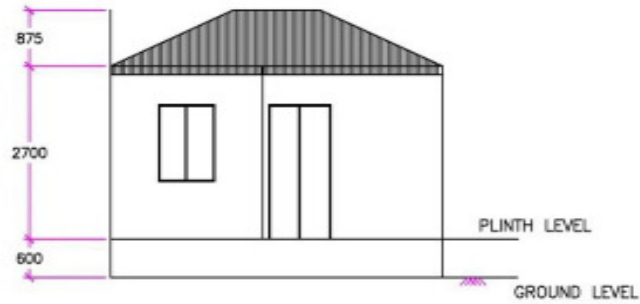

ELEVATION

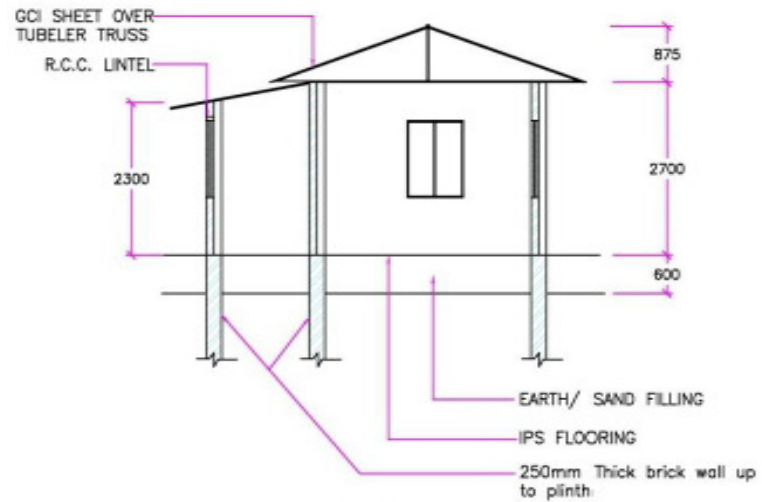

SECTION AT A-B

Basab Dewlling unit.jpg

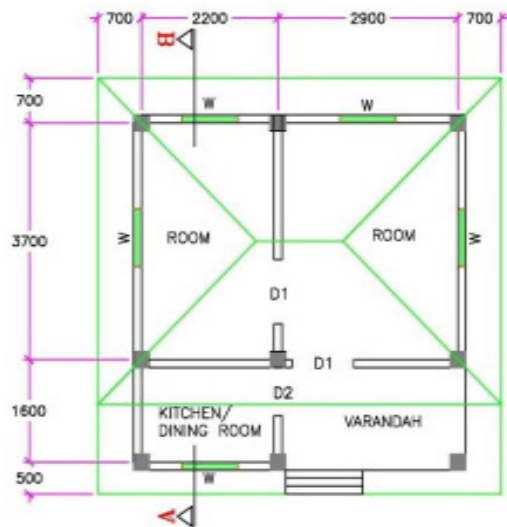

PLAN

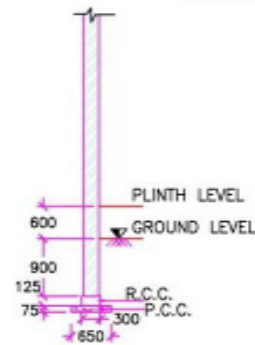

DETAILS OF FOUNDATION

SCHEDULE OF DOORS' & WINDOWS'

MKD.	DIMENSION	
	WIDTH	HEIGHT
D1	1000	2100
D2	750	2100
W	900	1200
PLINTH AREA 27Sq M.		

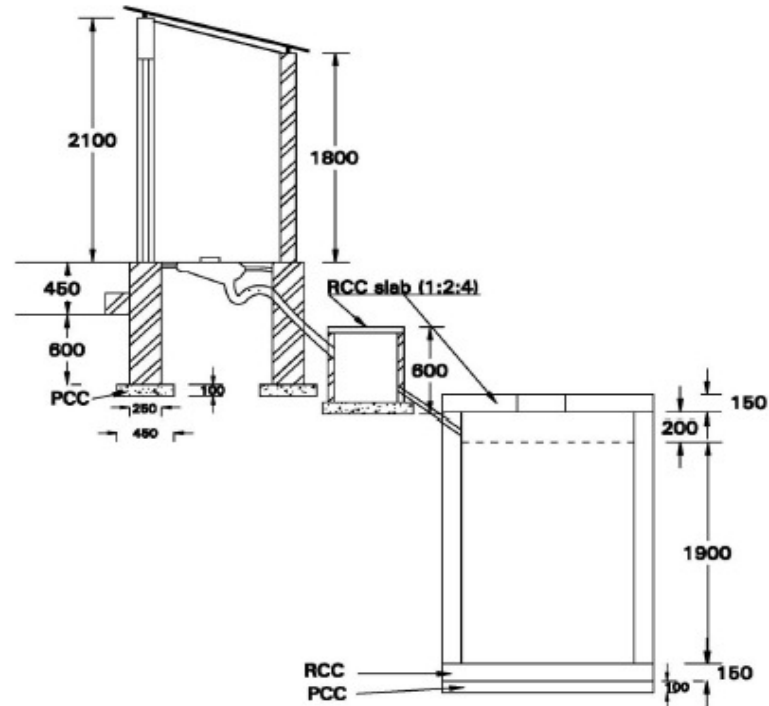

TYPICAL SECTION

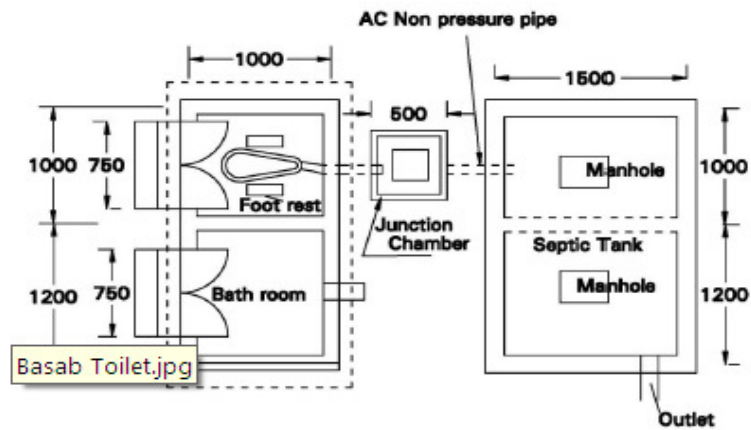

PLAN

INDIVIDUAL SANITATION BLOCK

Other Verticals:

- **CLSS**- Total demand assessed 5000 (application till date - 210)
- **Affordable Houses in Partnership** - Beneficiaries not having land are proposed to be covered under Affordable Houses in Partnership during 2018-19.
- **"In situ" Slum Redevelopment** - 94 Slum pockets identified in Agartala. Development plan being worked out.

Rajiv Awas Yojana (RAY)

(Sanction during 2015-16)

Issue	Status
No. of Projects	4 Nos.
No. of Dwelling Units sanctioned	3005 Nos.
Dwelling Units under progress	3005 Nos.
Dwelling Units Completed	657 Nos.
Total Occupied	657 Nos.
Project cost	Rs.98.80 crore.
Central Share	Rs.77.92 crore
Total ACA Received	Rs. 59.94 crore.
Total UC submitted	Rs. 58.66 crore.
Proposal for 3rd Installment sent	Rs.17.98 crore.
Expected Date of Completion	March, 2018.

Photograph of Houses constructed under RAY in Khowai Nagar Panchayat



Photograph of Houses constructed under RAY in Sabroom Nagar Panchayat



Photograph of Houses constructed under RAY in Amarpur Nagar Panchayat



Status of Basic Services to Urban Poor - **JNNURM (Sanction during 2007-8)**

Issue	Status
Name of the Project	Basic Services to Urban Poor(BSUP)
No. of Mission Cities	One (Agartala).
Total Project Cost Approved	Rs. 16.73 crore.
Total ACA committed & Released	Rs. 13.46 crore.
Total amount with ULB/IA	Rs. 16.73 crore.
Total Expenditure made by ULB/IA	Rs. 16.73 crore.
Total UC submitted GoI	Rs. 16.73 crore.
Total Dwelling Units Approved (N+U)	256 Dwelling Units.
Total DUs completed and Occupied	256 Dwelling Units.

Vivekananda Awasan: BSUP Project at Agartala



**Status of Integrated Housing and Slum
Development Programme – JNNURM**
(Sanction during 2009-10)

Issue	Status
Name of the Project	Integrated Housing and Slum Development Programme (IHSDP)
No. of Projects	5(five) Numbers.
No. of Towns/Cities Covered	5(five) Numbers.
Total Project Cost Approved	43.64 crore.
Total ACA committed and released	38.05 crore.
Total Amount with ULB/IA	43.64 crore.
Total Expenditure made by ULB/IA	43.64 crore.
Total UC submitted	43.64 crore.
Total DUs Approved (N+U)	3115 Numbers.
Total DUs completed and Occupied	3115 Numbers.

Houses under IHSDP Projects

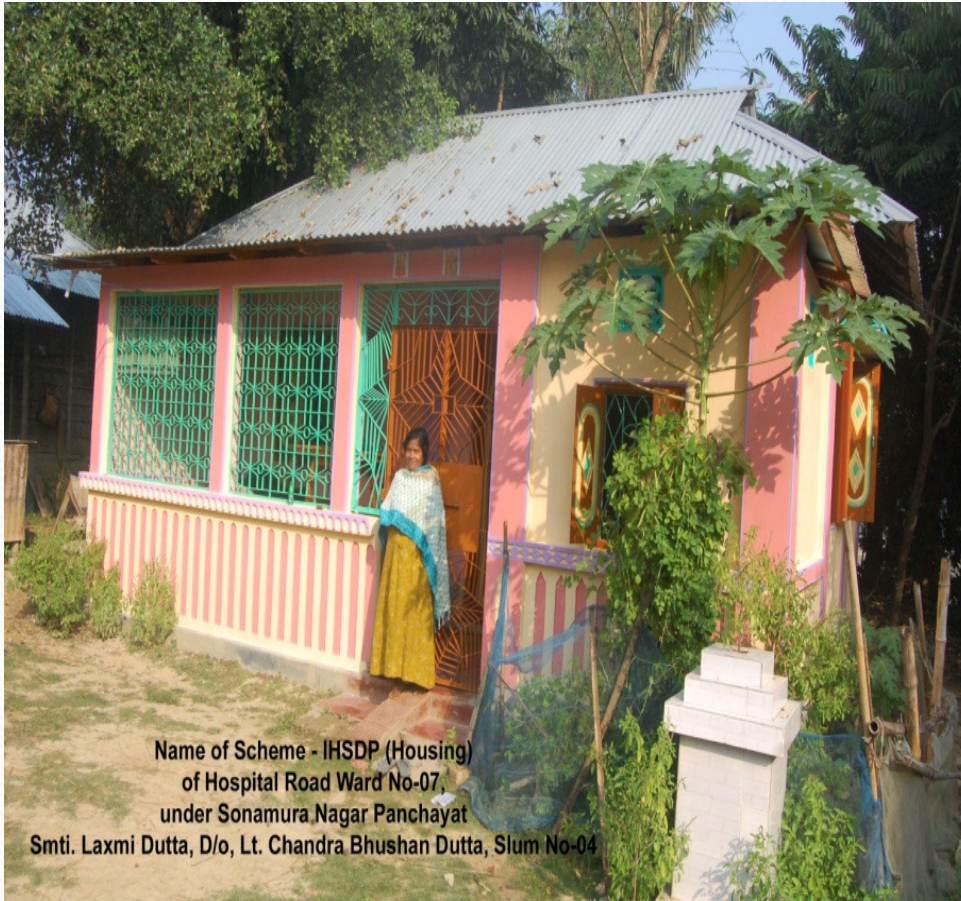

Name of Scheme - IHSDP (Housing)
of Hospital Road Ward No-07,
under Sonamura Nagar Panchayat
Smti. Laxmi Dutta, D/o, Lt. Chandra Bhushan Dutta, Slum No-04



CB and Social Audit Plan

- **Establishment of State Level Technical Cell (SLTC):-**7 (seven) numbers of professionals.
- **City Level Technical Cell (CLTC):-**For 19 ULBs City Level Professionals @ 2 per ULB and for Agartala Municipal Corporation @ 4 totaling 42 professionals.
- **Training and Workshops:-**For 20 ULBs at city level and state level, 5 & 3 numbers of workshops totaling 8 workshops.
- **Exposure visits:-**For 20 ULBs- 8 numbers of exposure visits.
- **Documentation/ Research:-** Tripura Institute of Technology (TIT) and National Institute of Technology (NIT) approached.
- **Information Education & Communication (IEC) Plan:-** IEC plan chalked out in conformity with IEC guidelines, 2017.
- **Third Party Quality Monitoring (TPQM):-** National Institute of Technology (NIT) and Tripura Institute of Technology (TIT) started quality monitoring.

Social Audit Plan-

1	Name of State/UT	Tripura	
2	Total number of projects approved under HFA Mission in the state	20	
3	Total number of projects selected for Social Audit	20	
4	Number of dwelling units to be covered in the social audit	32,699	
6	Name and address of the Independent Facilitating Agency shortlisted	Tripura Institute of technology(TIT), Narshingar/ National Institute of Technology (NIT), Jirania	
7	Tentative schedule of audit meetings	City	Date/Month
		All 20 ULBs	Between Dec, 2017- March, 2018

Thank You

Houses allotted to vulnerable section



Consolidate budget for CB and SA Plan

Sl. No.	Activity	Budget (Rs. in Lakhs)
1	Establishment of SLTC	62.40
2	Establishment of CLTC	178.80
3	Trainings and Workshops	11.00
4	Exposure Visits	24.00
5	Documentation/Research	5.00
6	IEC	35.00
7	TPQM	26.64
8	Social Audit	11.00
	Total	353.84

Foot Note: Release of fund for Supervisor and Surveyors awaited from Ministry, Rs. 42.89 lacks
2. Fund under A & OE @1% central release to the state in the corresponding year is awaited.